

CRAZY DREAMS

Lap: 48" x 60" • DBL: 72" x 84" • Queen: 96" x 108"



CRAZY DREAMS...

Crazy Dreams, a new twist on the old traditional Crazy Quilt! Featuring a celestial motif, this pattern provides creative block piecing methods in addition to fast and easy fusible appliqué instructions.

For the Crazy quilt blocks & side triangles, choose an assortment of blue prints in medium to dark values.

QUILT TOP:	LAP	DBL	QUEEN
Finished Size:	48" x 60"	72" X 84"	96" X 108"
Blocks	8 of 1/3 yd ea	11 of 2/3 yd ea	10 of 1-1/3 yds ea
Side Triangles	1-1/3 yd	1-3/4 yd	2-1/4 yd
Binding	1/2 yd	3/4 yd	7/8 yd
Backing	3 yds	5 yds	9-3/4 yds

Paper for templates:

12" squares.....3.....8.....12

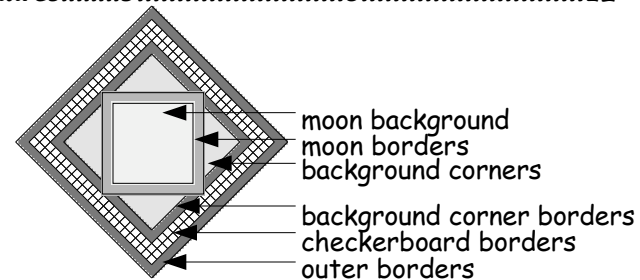

PIECED CENTER UNIT:

Moon	18" Square
Gold Stars	4 squares, 9" x 9" each
Silver or White Star	1 square, 9" x 9"
Purple Moon Background	1 square, 12" x 12"
Moon Border	1/8 yd Black
Background Corners	1/3 yd Purple cotton or Lame
Corner Borders	1/4 yd Bright Blue
Checker Board Border	1/4 yd each of Black & Yellow
Outer Purple Border	1/4 yd
Fusible web	1 yd

CRAZY DREAMS

Copyright 2000 Karla Alexander

CUTTING INSTRUCTIONS

Cut all strips across the fabric width, cross grain - approximately 40" to 42" wide.

Center Medallion..	First Cut.....	Second Cut
Moon Background.....	12" square	
Moon Border.....	cut 2 strips, 1-1/2"	
" "	cut 2 strips, 12" x 1-1/2"
" "	cut 2 strips, 14" x 1-1/2"
Background Corners,	cut (2) squares, 9" x 9"	cross cut diagonally 
Corner Borders,	cut 4 strips, 1-1/2"	
" "	cut 4 strips, 1-1/2" x 10"
" "	cut 4 strips, 1-1/2" x 12"
Checker Board Border, cut 4 light strips, 1-1/2"		
Checker Board Border, cut 4 dark strips, 1-1/2"		
Outer Border,	cut 4 strips, 2" wide	
" "	cut 2 strips, 2" x 23-1/2"
" "	cut 2 strips, 2" x 26-1/2"

Number of strips for:.....LAP..... DBL..... QUEEN

Crazy Blocks:			
Cut strips, 11" x width of fabric.....	8.....	22.....	40
cross cut strips into 11" squares.....	24.....	64.....	120
Setting Triangles, cut strips 15" x width of fabric.....	3.....	4.....	5
Cross cut into 15" squares.....	5.....	8.....	9
Cut each square on both diagonals (4 triangles each).....	20.....	32.....	36 
Binding cut strips 2-1/2" x width of fabric.....	6.....	8.....	12

GENERAL INSTRUCTIONS:

- Please read throughout the pattern before beginning.
- The following instructions are based on making a Lap size quilt. For a Double or Queen size, make the required extra blocks & setting triangles, see "Cutting Instructions" above & refer to the quilt lay out on page 5.
- Press block seams toward whichever side creates the least amount of bulk.
- "Right sides together" has been abbreviated as 'RST.'
- All seams are 1/4" unless noted otherwise.
- "Chain sewing" is used throughout the pattern. This method uses a 1/4" seam allowance along the raw edges of 2 pieces of fabric. With RST, sew the entire length of 2 pieces of fabric. Without cutting the thread, take a few stitches without any fabric under the needle. This creates a short chain approximately 1/8" long. Feed the next set of pieces through the sewing machine until all "like" sets have been stitched together.

Center Medallion

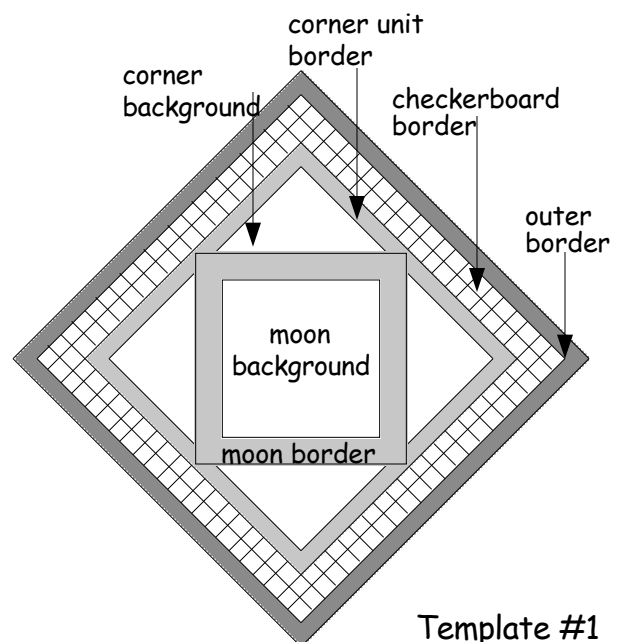

Step 1, crazy blocks:



Templates:

1. Read through the following methods to determine which works best for you. You can choose to make each of your templates the same or make them all different.

- **METHOD 1:** This method gives you the option of using Template #1 and, or #2. Draw each to scale in order fit an 11" square of paper or, enlarge the template on page 5 by 366%.
- **METHOD 2:** With this method, you can design your own template. Start with an 11" square of paper & draw a line separating the square into 5 different sections. Number the sections in the order of which they can be sewn together.
- **METHOD 3:** With this method you won't need a template, just be creative, (...or brave) & cut your stack of fabric into 5 separate sections.

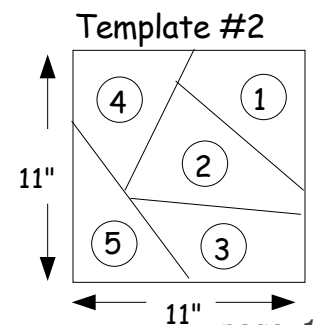
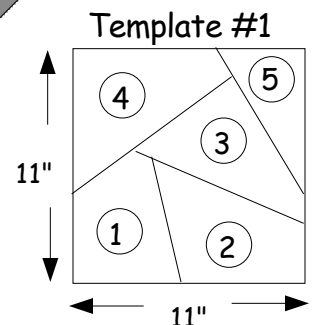

2. On a separate piece of paper, draw a smaller version of each template you decide to use & set them aside. These will be used as a reference guide only & does not need to be drawn to scale.

3. Divide the fabric squares for the crazy blocks into 3 stacks of 8 each for the lap size. For a DBL size quilt, you will need 8 stacks of 8 each, & for a Queen size quilt you will need 12 stacks of 10 each.

- Work any extra squares into the fabric stacks, you can have as many as 12 squares in any one stack.
- Make sure there are no duplications of the same fabric in the same stack.
- Alternate light, medium & dark values. Keep in mind that the fabric on the top of the stack will eventually touch the fabric on the bottom of the stack, therefore also need to be contrasting.

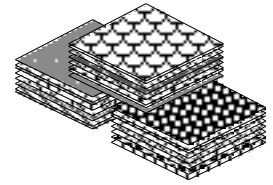

4. Choose 1 stack of fabric squares & set the others aside. Place a template on the fabric stack. Secure each numbered section, through all layers, with a straight pin.

5. Use a rotary cutter & cut the stack of squares apart on the template lines. Cut through the paper & all layers of fabric. You should have 5 different sections.

6. After cutting, remove the pins & template. Reassemble the template to the side of cut sections for reference later.

Shifting the stack: (see Diagram 1)

1. This method shifts the entire stack so that every level has 5 different fabrics. Beginning with section number 1, take the 1st layer off the top & place it directly on the bottom of that stack.

2. SECURE A SAFETY PIN IN THE **NEW** TOP LAYER OF SECTION #1. THIS HELPS IDENTIFY LAYER # 1 & KEEPS SECTIONS IN THE CORRECT SEQUENCE THROUGHOUT SEWING PROCESS.

3. Next, take 2 layers off the top of section #2 & place directly on the bottom of that stack.

4. Next, take 3 layers off the top of section #3 & place directly on the bottom of that stack. Continue in this manner until all blocks have been shifted.

5. Pin each disassembled template section (from step #7 above), to the bottom of its corresponding fabric sections, (pin through all layers). This helps guarantee the correct order is maintained throughout sewing process.

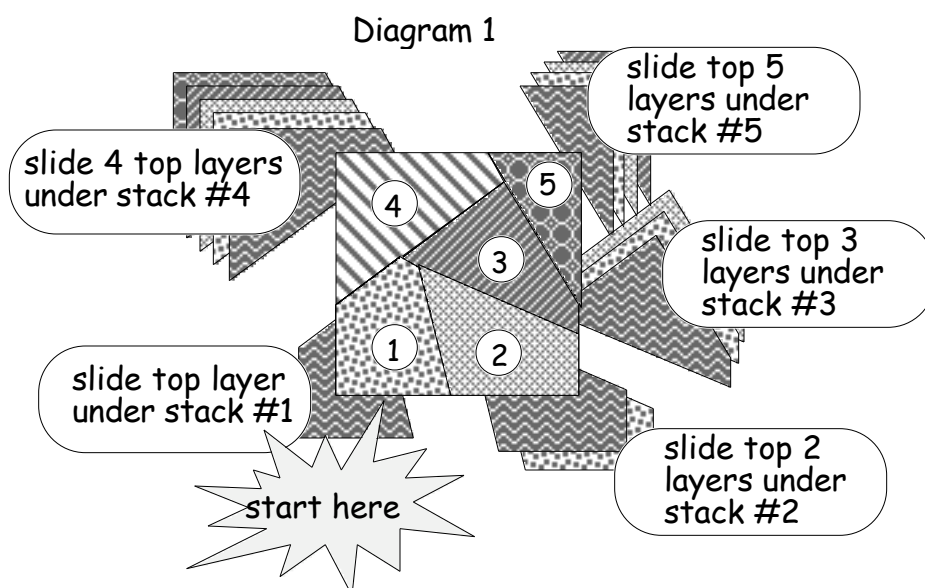

CAUTION: Fabric sections are easily confused if dropped or rotated. Secure a pin through all the layers of each section (until ready to sew) & keep a reference template in view to assure correct placement in the event of a mix-up.

Block Assembly:

Edges of combined sections will not match up. Block will be squared up after all 5 pieces have been joined together.

1. Beginning with the top layer of the stack, flip section 2 RST with section 1 & stitch together. Pick up the next layer of sections 1 & 2, & stitch together as shown in Diagram 2. Continue chain stitching until all layers of section 1 & 2 have been sewn together.

2. Carefully clip chain-stitched sets apart (before or after pressing), & re-stack in the **exact** order in which they were sewn. (Top one should have a pin.)

3. Flip the first layer of section 3, RST, with combined top layer sections 1 & 2. Chain-stitch until all layers of section 3 have been sewn to combined sections 1 & 2. See Diagram 3. Press & re-stack as in step 2. Make sure sections stay in the exact order in which they were sewn.

4. Repeat above with remaining sections 4 & 5.

5. Use a square ruler & trim the pieced blocks into a 9" square. See Diagram 4. Set blocks aside. This completes the Crazy block assembly.

Diagram 2

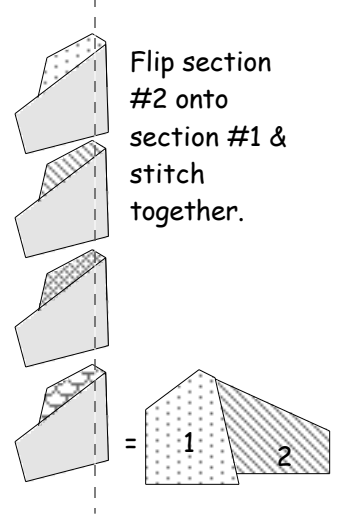

Diagram 3

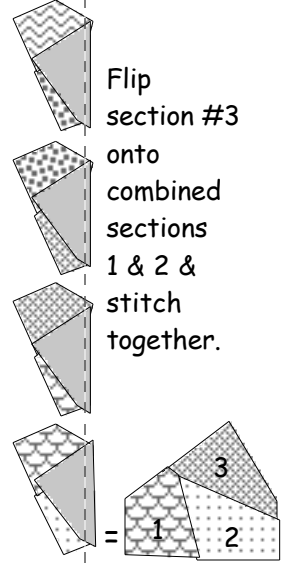
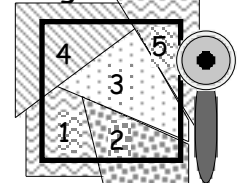

Diagram 4



STEP 2: Pieced Center Block - Unit A/B

Unit A: Moon Background & Border:

1. Cut the fabric for moon background & border. Stitch a 1-1/2" x 12" border strip to 2 opposite sides of the 12" center background square. Press.

2. Stitch a 1-1/2" x 14" border strip to the top & bottom of the square, forming Unit A. Press & set aside.

UNIT B - Corner Backgrounds & Borders:

1. Cut the fabric for the corner backgrounds & borders. Stitch a 1-1/2" x 10" strip to one straight grain edge of each corner triangle. Repeat on other straight grain edge using a 1-1/2" x 12" strip. Press & trim edges even. See Diagram 5.

2. Center & stitch 2 Unit B setting triangles to 2 opposite sides of Unit A, (edges will overlap approximately 3/4"). Press. Next, stitch a Unit B setting triangle to both the top & bottom of Unit A. Press. Block should measure approximately 19-1/2" square. Set aside.

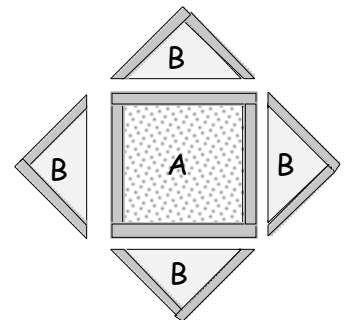
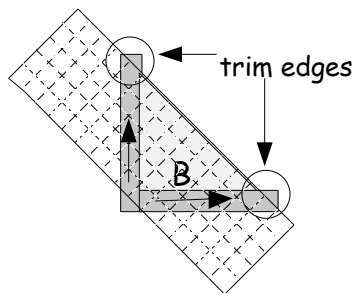
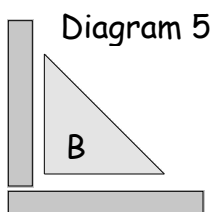

Checkerboard & Outer Borders:

1. Cut the strips for the checkerboard border. Alternate 2 black strips with 2 yellow strips & sew RST. Change sewing direction with each newly added strip. Press seams toward the dark fabric. Make 2 sets.

2. Cut strip sets into thirds, (approximately 14" long each) & re-sew together, side by side. See Diagram 6 & 7. Make 2 sets.

3. Cut the 12-1/2" x 14" strip set in half. Re-sew the halves together side by side to make 2 strip sets, 7" x 24-1/2" each. See Diagram 7 & 8.

Diagram 6
make 2 sets

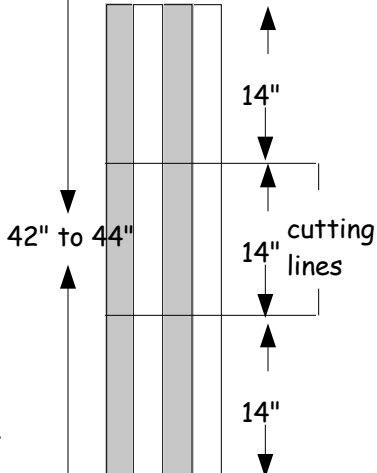
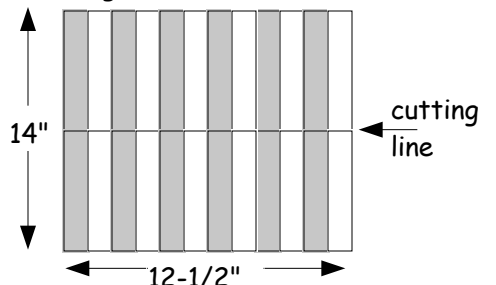
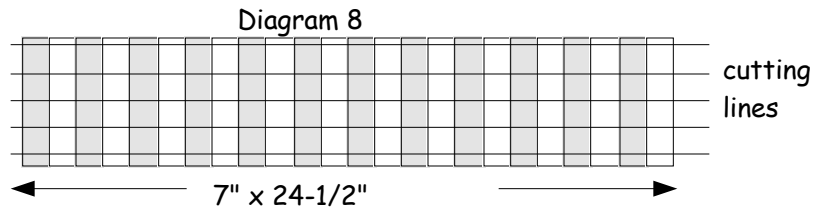

Diagram 7



4. Use a rotary cutter & cut (4) 1-1/2" x 24-1/2" strips from each set. You should have 8 strip sets, each yielding at least 24 squares. See Diagram 8.



5. Take 4 strip sets from step #4 above & remove 5 squares from the right side of the first 2 strip sets. Remove 5 squares from the left side of the remaining 2 strip sets. Each set should have 19 squares. See Diagram 9.



7. Take remaining 4 strip sets from step #4 above & remove 1 square from the right side of the first 2 strip sets. Remove 1 square from the left side of remaining 2 strip sets. Each set should have 23 squares. See Diagram 10.



8. Repeat stitching as in step #6 above, making 2 long checkerboard borders.

9. Pin & fit the checkerboard borders onto UNIT A/B from Step #2 above. Add the short borders to 2 opposite sides first & the long ones to the top & bottom last. Press. If the borders need to be adjusted more than 1/4", make adjustments by taking in or letting out a few of the checkerboard seam allowances.

10. For the outer border, add a short purple strip to the right & left side of Unit A/B. Next, add a long purple strip to both the top & bottom of Unit A/B. Press.

11. You can choose to appliqué the moon & silver star on the center pieced unit before or after quilt top is assembled. Skip to "Moon & Star Appliqué" below for instructions.

Step 3 - Quilt Top Assembly:

1. Assemble the blocks and pieced center unit on a large flat surface. Rotate the blocks & balance color as desired. See Diagram 11.

2. Fill in the edges with the setting triangles. The setting triangles are oversized & can be trimmed away later.

3. Sew the setting triangles into place first & then sew the blocks into rows. See Diagram 11. Press.

4. Join the rows & center unit together as shown. See Diagram 11. Press.

Diagram 11

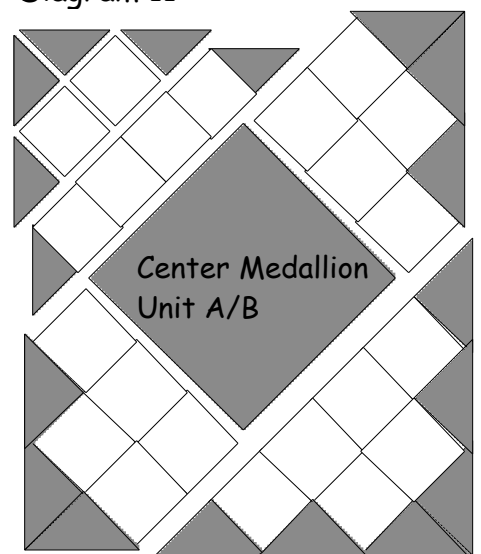

Moon & Stars Appliqué:

1. Trace the moon and 5 stars (see page 5), onto the paper side of the fusible web. Your design will be the mirror image of the provided pattern, but when finished will be the same image as the finished project in the quilt.

2. Cut loosely around the traced designs on the fusible web. Do not cut on the tracing lines at this point.

3. Fuse fusible web to wrong sides of selected fabrics & cut out on tracing lines. Arrange shapes in desired positions & fuse in place according to manufacturer's directions.

4. Use a buttonhole or satin stitch to machine appliqué the shapes in place.

Step 4 - Finishing:

1. Layer backing, batting & top together. Pin or spray baste and quilt as desired.
2. Trim quilt edges straight along with any excess batting and backing. Remove selvages and join binding strips, short end to short end, making one long piece. Press seam allowance open to reduce bulk. Press joined strips in half lengthwise, wrong sides together. Press one short end of binding under 1/4".
3. Lay the binding on front of the quilt, aligning raw edges. Place the end of the binding approximately 5" from a corner. With a 1/4" seam allowance, begin stitching 3" from the folded end of the binding, leaving an unsewn tail. Stop 1/4" from the corner and backstitch.
4. Fold the binding up, then back down, even along the second edge of quilt. A little pleat will form at the corner.
5. Start stitching at the folded edge. Continue stitching around the quilt until you are 3" from the starting point. Trim binding so it overlaps the beginning by 1". Tuck cut end inside the fold and whip stitch closed. Finish sewing the binding to the quilt.
6. Fold binding around edge of quilt back and hand-stitch in place.

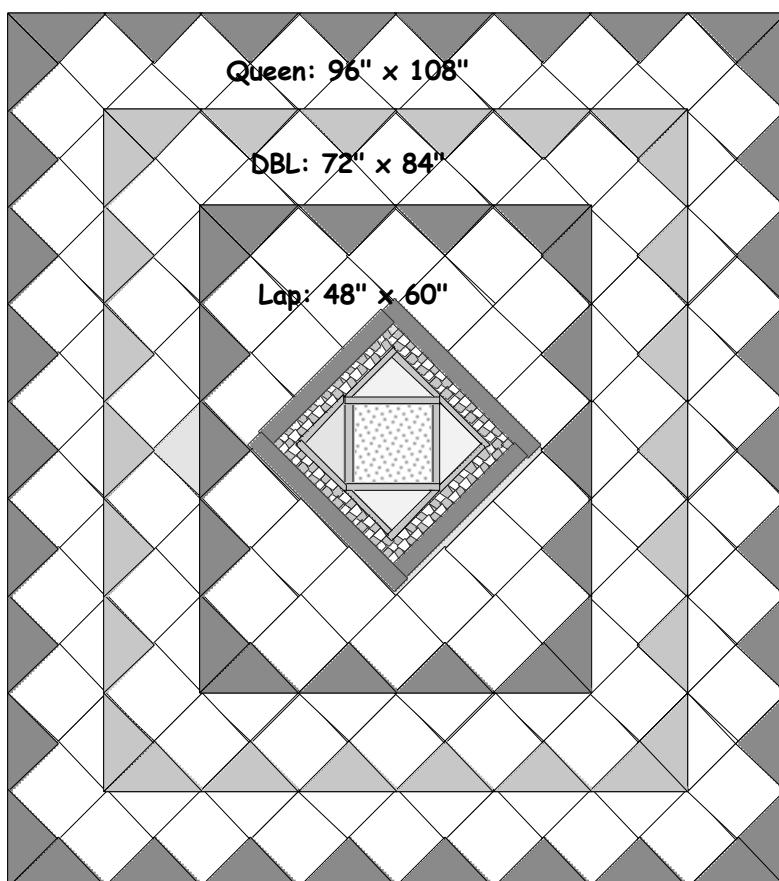
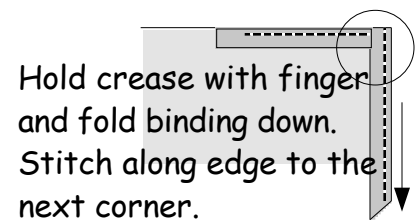
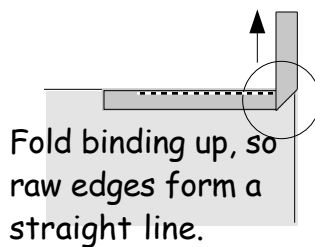

Enlarge by 366% for an 11" template, or draw to scale to fit an 11" square.

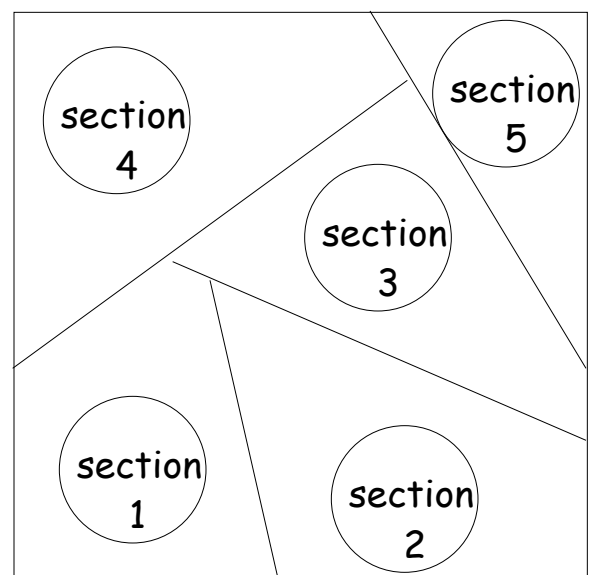

All the information in this pattern is presented in good faith, diagrams & text have all been carefully checked & cross-checked however, no warranty is given nor results guaranteed. Due to the variability of materials & personal skill, etc., author assumes no responsibility for damages or other losses incurred that result from the material presented herein.

Copyright 2000 • by Karla Alexander • saginawstreetquilts.com

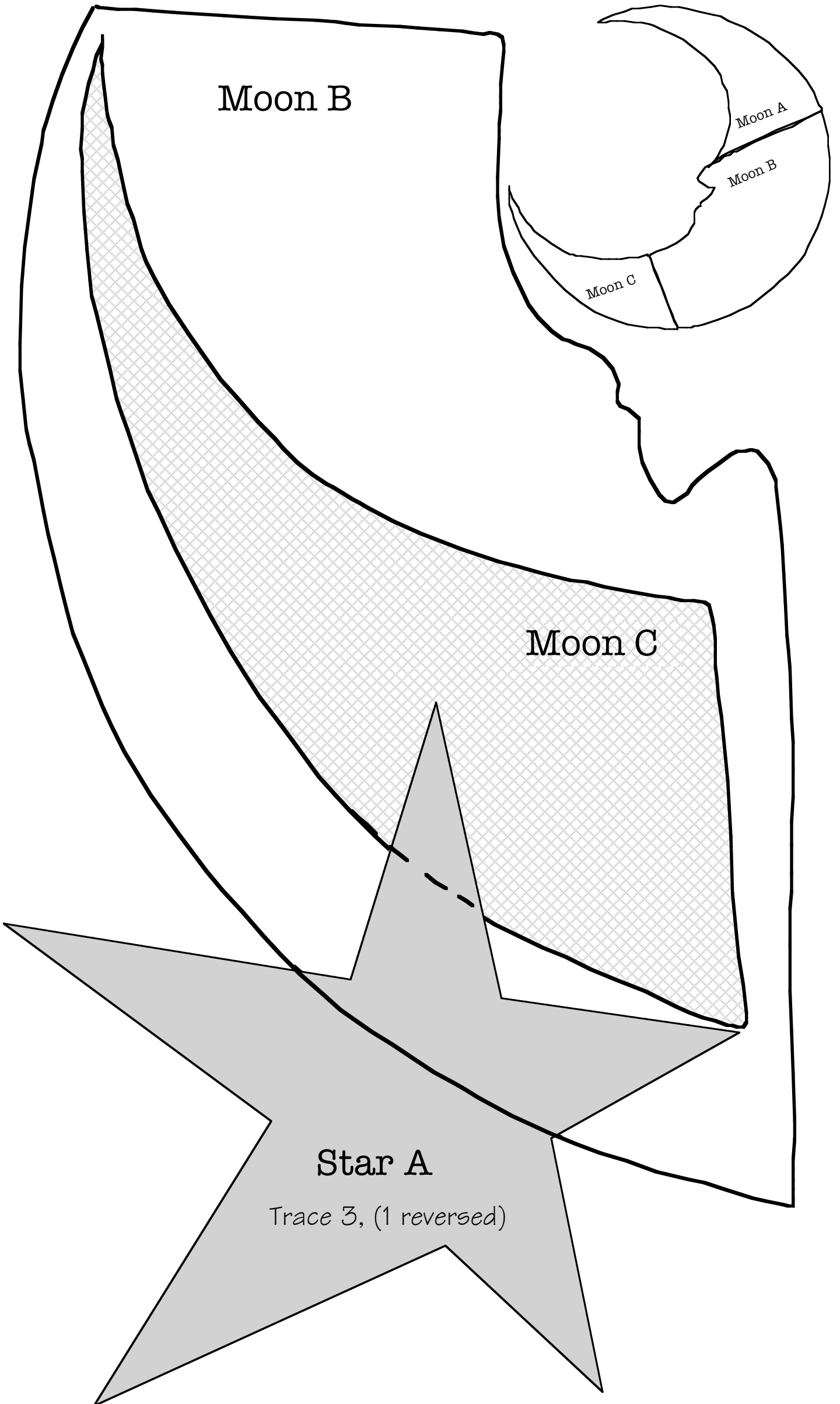

Moon B

Moon A

Moon B

Moon C

Moon C

Star A

Trace 3, (1 reversed)

Moon A

TIP: Choose which ever star you want for the center silver star. Free form draw & use as many different stars & colors as you like!

Trace 2, (1 reversed)

Star B